

## DATA SHEET



### CONTACT

KFA SARL  
4 CHEMIN DE LA SOURCE  
26260 CLÉRIEUX  
FRANCE

**PHONE** +33 (4) 75 71 64 17

**E-MAIL** [BLETZ@KFA-SARL.FR](mailto:BLETZ@KFA-SARL.FR)

## KFA3

4-wire TDR-Sensor with wire rope probe for continuous level measurement and point level detection in bulk solids, with analog and switching output.

### MEASUREMENT PRINCIPLE

KFA3 uses TDR (Time Domain Reflectometry) technology: low-energy, high-frequency electromagnetic impulses, generated by the sensor's circuitry, are propagated along the probe which is immersed in the bulk solids to be measured. When these impulses hit the surface of the solids, part of the impulse energy is reflected back up the probe to the circuitry which then calculates the level from the time difference between the impulses sent and the impulses reflected. The sensor can output the analysed level as a continuous measurement reading through its analog output, or it can convert the values into freely positionable switching output signals. TDR-Sensors are also known as Guided Radars or Guided Wave Radars (GWR).

### APPLICATION AREA

The innovative TDR technology enables direct, precise and highly reliable continuous level measurement as well as point level detection in almost every bulk solid – independent of changing process conditions (such as density, conductivity, temperature, pressure, moisture and dust). KFA3 has almost no installation restrictions – it can be mounted in small tanks as well as large silos, tall and narrow nozzles and it measures precisely even with difficult tank geometries or close to interfering structures.

### BENEFITS

- Unmatched price/performance ratio
- Precise continuous level measurement and reliable point level detection combined in one device
- Complete galvanic insulation of device electronics from its inputs/outputs and the tank potential (no problems with electrochemical corrosion protection)
- Highly robust measurement due to 4-wire design and innovative signal analysis and disturbance signal suppression

Figure 1: sensor components

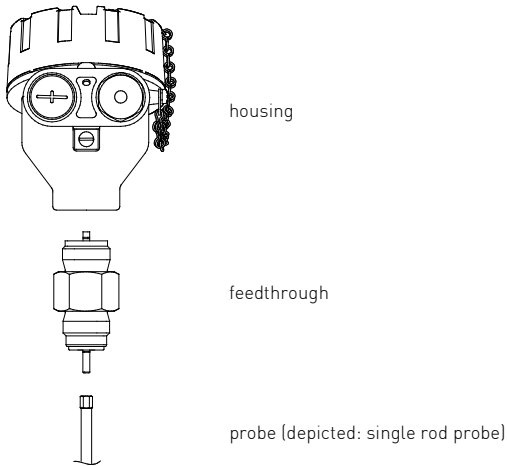

### SENSOR COMPONENTS AND PROBE TYPE

KFA3 consists of three major components: housing, feedthrough, and probe. The only components that are exposed to the atmosphere inside the tank are probe and the part of the feedthrough below the hexagon.

The housing contains the sensor's electronics and input/output terminals and has no contact to the tank atmosphere.

The so called feedthrough is mounted into the bottom of the housing and serves two main purposes: its outer threaded metal bushing securely connects the sensor to the tank and its inner components guide the high-frequency measurement signal from the electronics through the tank wall into the tank and back.

The probe is mounted onto the bottom of the feedthrough and gets immersed into the solids inside the tank; the high-frequency measurement signal is propagated along the probe.

KFA3 has a flexible modular concept: any probe can be used with any housing since they are joined together by one universal feedthrough.

Figure 2: probe type considerations

WIRE ROPE PROBE			
SINGLE ROD PROBE			
PROBE MOUNTING			
non-metallic tanks		•	•
limited headroom for installation		-	+
tall tanks		-	+
small tanks with light bulk solids		+	-
lateral force on the probe		-	+
+ = recommended			
• = possible, maybe with configuration and/or mounting adjustments			
- = not recommended			

To meet various application requirements, KFA3 has two different probe types: wire rope probe and single rod probe.

Wire rope and single rod probes are suitable for a very wide range of applications. However, the signal has a wider detection radius around the rope/rod. Thus, they are more responsive for measurement signal disturbances which can be easily overcome by observing a few mounting considerations and making simple configuration adjustments to the sensor.

The wire rope probe is the standard probe of the KFA3 and is recommended for installations in bulk solids, tall tanks and where limited headroom is available for installation (since the wire rope comes in a space-saving coil and can then be uncoiled into the tank).

The single rod probe is recommended for installations in smaller tanks with light bulk solids (such as loose powders or plastic granulates) that do not apply any major lateral forces onto the probe.

Figure 3: probe length and measuring range

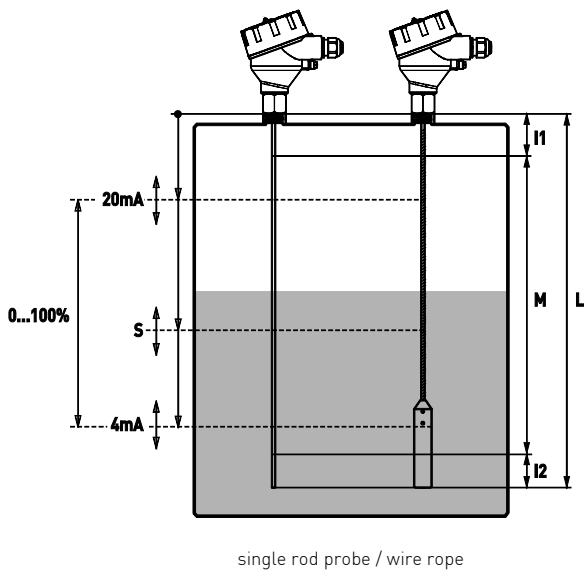

Figure 4: mounting

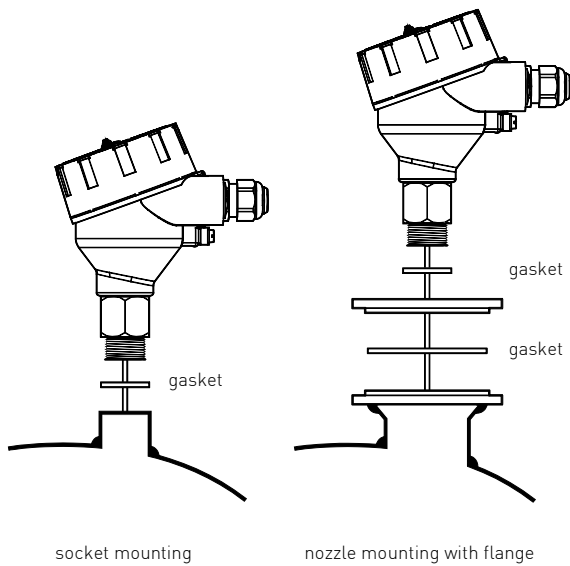

Figure 5: mounting considerations

WIRE ROPE / SINGLE ROD PROBE	
nozzle diameter	>50mm
nozzle height	<300mm
clearance to tank wall or other internal objects	>100mm
clearance between probe end and tank bottom	>2mm

### PROBE LENGTH AND MEASURING RANGE

The reference point for definition of the probe length [L] is always the shoulder of the connection thread. The probe length [L] is an important mechanical dimension which is needed to make sure the probe physically fits into the tank at the anticipated mounting location; it is not equal to the actual measuring range [M] of the sensor!

TDR level sensors have small inactive areas at top [I1] and bottom [I2] of the probe. Those are due to the presence of unavoidable signal disturbances at both ends of the probe. In these inactive areas the measurements are non-linear or have reduced accuracy. Therefore, it is not recommended to actually measure level within those inactive areas. Their length depends on the probe type and the reflectivity (i.e. dielectric constant) of the bulk solid to be measured.

The measuring range [M] of KFA3 extends between the top and bottom inactive areas of the probe; this is the area in which KFA3 will have the specified measurement performance. It is recommended that the maximum and minimum levels to be measured in the tank are actually within the measuring range [M] of the sensor. The span between the lower range value [4mA] and the upper range value [20mA] of the analog current output is equal to 0...100% of your continuous level measurement reading. It is recommended that the span between those two range values stays within the measuring range [M]. The location of the switching point [S] of the switching output can also be freely positioned within the measuring range [M]. Fixed hysteresis or separate upper and lower thresholds can be defined for the switching output.

### MOUNTING

KFA3 is mounted vertically to the tank via its connection thread, which is screwed directly into a standard threaded tank connection, i.e. weld-in socket, or it can be screwed into a flange, which is then connected to a tank nozzle. The customer has to ensure proper temperature and pressure ratings for his application and has to select the appropriate seal to connect the sensor (KFA3 comes with a Klingersil C-4400 gasket).

The probe should be installed so that they are not directly impacted by solids flowing out of the filling inlet.

The wire rope probe should hang down into the tank, all the way straight to the bottom. The counterweight at the end of the wire rope probe is intended to be embedded into the bulk solid, thus ensuring a tensile force onto the wire rope which will keep the probe straight.

For further details about mounting KFA3 or if you would like to anchor the probes, please contact your local distributor or KFA directly.

Figure 6: electrical connection

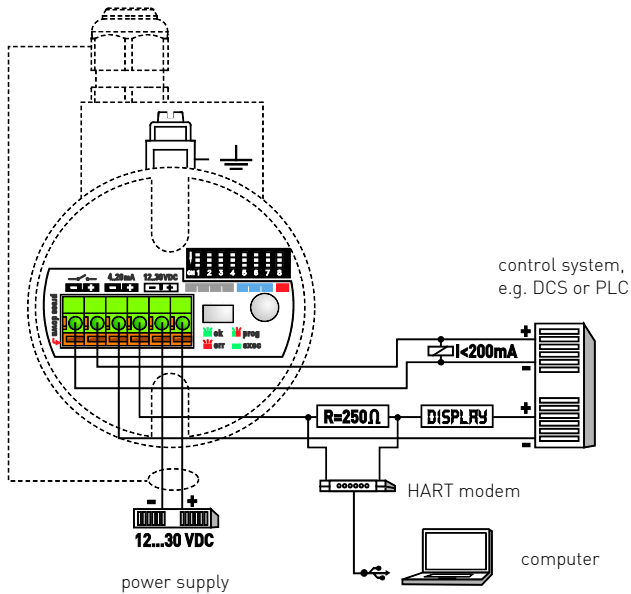

## ELECTRICAL CONNECTION

KFA3 is a 4-wire system: a set of 2 wires for the power supply and separate sets of 2 wires for each output.

The wires are connected to the sensor electronic inside the housing via a screwless, cage clamp terminal block for stranded and solid wires 0,5...2mm<sup>2</sup> / AWG 22...14.

The housing has two cable entries and can be ordered with assembled standard screw plugs and cable glands. Nevertheless, the customer has to confirm the suitability of those cable glands for his specific application requirements and cabling; and replace them when necessary. IP68-rated screw plugs and cable glands have to be properly mounted (with rubber washers underneath) and have to be properly tightened around cable of suitable type and diameter to ensure the IP68 rating of the housing.

KFA3's electronic is galvanically completely insulated from its inputs/outputs and the tank potential; thus avoiding any problems from electrochemical corrosion protection of the tank.

## CONFIGURATION

Basic configuration of KFA3 can be done directly on the device via a DIP switch, a single push button and visual feedback from an LED. All settings required to get KFA3 fully operational can be performed directly on the device; or KFA3 can be ordered completely pre-configured.

For greater convenience, remote configuration, and extensive diagnostics a simple EXCEL spread sheet is provided through which the configuration can be done.

A standard HART modem is required for communication between computer and sensor. Communication happens via a digital HART signal that is superimposed onto the analog 4...20mA signal of the current output.

<b>ELECTRICAL SPECIFICATIONS</b>		4-wire system
Output functions	continuous level measurement through analog output and point level detection through switching output	
Analog output (active)	current output 4...20mA the span between the lower range value [4mA] and the upper range value [20mA] is equal to 0...100% of the continuous level measurement reading. It is recommended that the span between those two range values stays within the measuring range [M]	
Total load resistance	<500Ω: HART resistor approx. 250Ω + load resistance approx. 250Ω if the current output is connected to a device with an inner resistance of approx. 250Ω, then there is no additional, external HART resistor necessary. In that case, the HART modem is connected in parallel to the current output wires	
Lower range value	4,0mA (span 0%)	
Upper range value	20,0mA (span 100%)	
Response time	0,5s [default], 2s, 5s (selectable)	
Temperature drift	<0,2mm/K change in ambient temperature	
Switching output DC PNP (active)	NC [default] or NO (short-circuit protected)	
Load current	<200mA	
Signal voltage HIGH	supply voltage - 2V	
Signal voltage LOW	0V...1V	
Response time	<100ms	
Supply voltage	12...30VDC (reverse-polarity protected)	
Current consumption	<50mA at 24VDC (no burden)	
Start-up time	<6s	
Cable terminals	screwless, cage clamp terminal block for stranded and solid wires 0,5...2mm <sup>2</sup> / AWG 22...14 the usage of cable end sleeves with insulation collar is not recommended	

<b>MEASUREMENT SPECIFICATIONS</b>		reference condition: dielectric constant [ε <sub>r</sub> ]=80, water surface, tank Ø1m, DN200 metal flange
Accuracy	±3mm or 0.03% of measured distance, whichever is greatest	
Repeatability	<2mm	
Resolution	<1mm	
Probe type	wire rope Ø6mm, type 7x19 single rod Ø8mm	max. tensile load: 10kN max. lateral load: 6Nm = 0.2kg at 3 m
Probe length [L]	wire rope probe: 1.000...20.000mm single rod probe: 100...3.000mm can be ordered in 5mm increments the reference point is always the shoulder of the connection thread (see dimensional drawings)	longer length on request
Inactive area top [I1]	wire rope probe, ε <sub>r</sub> =80: 80mm single rod probe, ε <sub>r</sub> =80: 80mm	wire rope probe, ε <sub>r</sub> =2: 120mm single rod probe, ε <sub>r</sub> =2: 120mm
Inactive areas bottom [I2]	wire rope probe, ε <sub>r</sub> =80: 30mm single rod probe, ε <sub>r</sub> =80: 30mm	wire rope probe, ε <sub>r</sub> =2: 80mm single rod probe, ε <sub>r</sub> =2: 80mm
Measuring range [M]	probe length [L] less both inactive areas at top and bottom [I1 and I2] in this range KFA3 will have the specified measurement performance. It is recommended that the maximum and minimum liquid levels to be measured in the tank are actually within the measuring range [M] of the sensor	
Lower [4mA] and upper [20mA] signal level	[default]: 4mA are set at 10mm above probe end, 20mA are set at 50mm below reference point	
Switching point [S]	freely positionable within the measuring range [M] hysteresis can be set by defining separate upper and lower thresholds; if those are set at the same position, the minimum hysteresis of 3mm applies	
Hysteresis	[default]: switching point is set at 20% of probe length [L], from reference point downwards	

<b>APPLICATION SPECIFICATIONS</b>	
	continuous level measurement and point level detection in bulk solids
Dielectric constant [ $\epsilon_r$ ]	wire rope / single rod probe: >1,6
Conductivity	no restrictions
Density	no restrictions
Dynamic viscosity	wire rope / single rod probe: <5.000mPa s = 5.000cP
Application temperature	wire rope / single rod probe: -40°C...+150°C
Ambient temperature	operation: -25°C...+80°C      storage: -40°C...+85°C
Application pressure	-1bar...40bar
Velocity of level change	<1.000mm/s

## MECHANICAL SPECIFICATIONS

Material exposed to tank atmosphere	1.4404 / 304, PEEK, o-ring (see order code) gasket at connection thread: Klingersil C-4400, 3mm thick other materials on request
Materials housing	housing body and cover: <ul style="list-style-type: none"> <li>aluminium alloy EN AC-ALSi9Cu3 (DIN EN 1706), epoxy spray coating (~70µm) other alloys and coatings on request</li> <li>stainless steel 1.4401 / 316</li> </ul> cover o-ring: silicone rubber (Elastosil R 750/50) other o-ring materials on request
Housing rating	cover safety chain / screws; cover locking screw; nameplate / rivots: 1.4301 / 304 external earth terminal / screw: tin plated stainless steel 1.4301 / 304 IP68, NEMA6P device cover has to be properly tightened and IP68 screw plugs and cable glands have to be properly mounted (with sealing) and have to be properly tightened around cable of suitable type and diameter the cover has a locking screw (allen key size 1,5mm) and a safety chain to prevent it from falling to the ground after being unscrewed
Cable entries [D2/ D3]	2 cable entries M20x1,5      other dimensions on request
Cable glands / screw plugs	<ul style="list-style-type: none"> <li>[D2]: cable gland, M20x1,5, IP68, nylon PA66, for non-armoured cable Ø5...9mm, with EPDM washer, max. tightening torque 6Nm, wrench size 24mm. For protection during shipment closed with EPDM sealing plug (to be removed for cabling)</li> <li>[D3]: screw plug, IP68, M20x1,5, nylon PA66, with EPDM washer other cable glands / screw plugs on request</li> <li>[D2] and [D3]: protective plugs, PE-LD, not IP68, only for housing protection during shipment, to be replaced by customer</li> </ul>
Connection thread [CT]	G1A or 1"NPT (wrench size 46mm)      other connection threads on request
Weight	aluminium housing (empty): 650g; stainless steel housing (empty): 1.270g electronics: 70g; feedthrough: 370 wire rope probe, 1m (no counterweight): 150g; counterweight: 760g



